

Maximum # of Ropes:

- SW 1/2" - 10
- DW 1/2" - 6
- SW 5/8" - 8
- DW 5/8" - 5
- 3/4" - 7
- 8mm - 14
- 10mm - 12

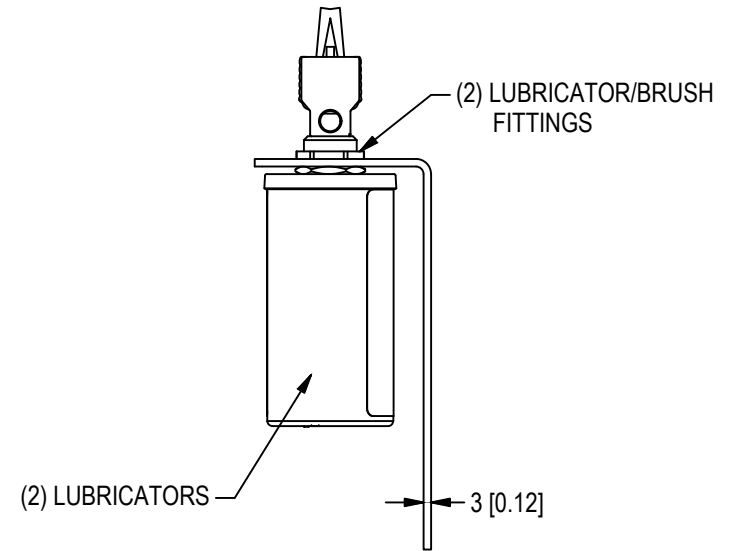
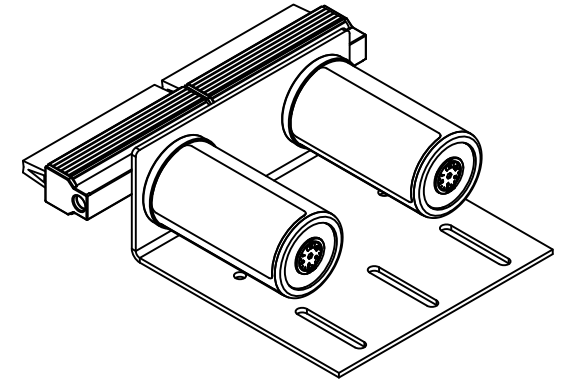

Copyright - All information contained in this drawing is property of Torin Drive North America

DRAWING No: RLU-KIT-20		Sheet 1 of 1	
DESCRIPTION: AUTOMATIC LUBRICATOR WITH 2 BRUSHES (200MM)		MATERIALS: ASSEMBLY	
		Scale: 1:3	
All Dimensions are in mm [inches]			
Date	Rev.	ECO#	Des/App
05/23/22	-	-	JY/SY

GENERAL TOLERANCES:

- >6-30mm: ±0.2 [0.008]
- >30-120mm: ±0.3[0.012]
- >120-400mm: ±0.5[0.020]
- >400-1000mm: ±0.8[0.031]
- >1000-2000mm: ±1.2[0.047]

UNLESS SHOWN OTHERWISE

www.torindrivena.com
 4949 E. Raines Road #101
 Memphis, TN 38118
 Phone: 1-877-622-2888
 Fax: 901-290-1680