

Armor 4BB (10) 1.25" Anchors

Left Hand

Right Hand

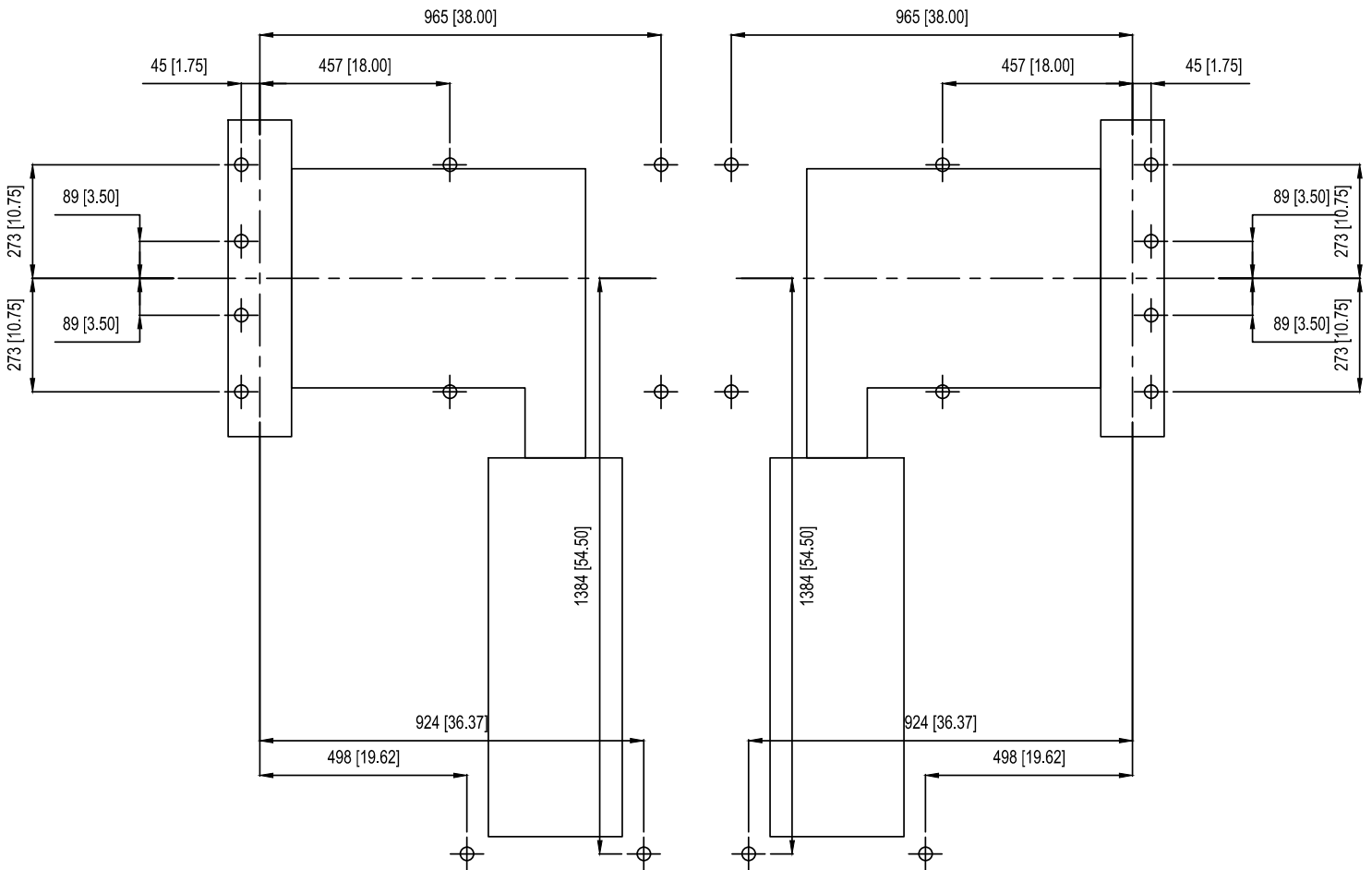

Please confirm all dimensions above are accurate.

All measurements are taken from the sheave centerline and sheave shaft centerline.

SES cannot be held responsible if on-site conditions differ from drawing above unless revised anchor drawing is approved.

TORINDRIVE

NORTH AMERICA

A Brand of HYPERION

Basement Inputs (required for all configurations)	
Basement Configuration (see pages 4-6)	
Machine Hand	
Existing Machine / Anchor Pattern	
Existing Anchor Bolt Height	
Existing Anchors Fully Threaded	
Existing Sheave Diameter	
Existing Rope Diameter	
Existing Rope Number	
Existing Pitch	
A Configuration Inputs	
MR1	
MR2	
MR3	
MR4	
B Configuration Inputs	
MR1	
MR2	
MR3	
DF1	
DF2	
RD	
C Configuration Inputs	
MR1	
MR2	
MR3	
DF1	
DF2	
DF3	
DF4	

TORINDRIVE

NORTH AMERICA

A Brand of HYPERION

Overhead / Deflector / Compounding Sheave					
Location					
Sheave Type					
Quantity					
Sheave Diameter, D					
Max Allowable Width, W (in)					
Required Shaft Diameter, d (in) (if any)					
Shaft Type					
L1					
L2					
L3					
L4					
L5					
L6					

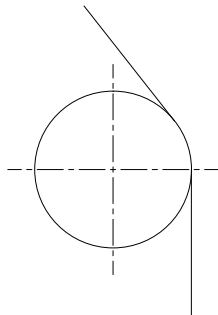

A
Deflector (<90° Wrap)

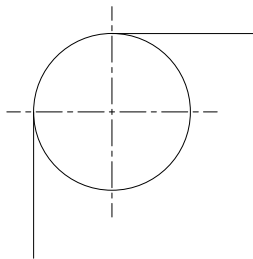

B
90° Wrap

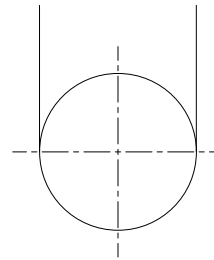

C
180° Wrap

Shaft Type A

Shaft Type B

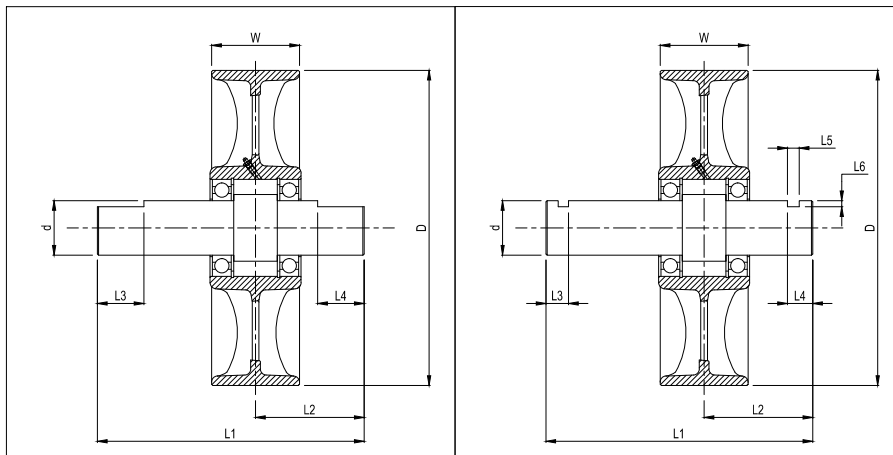

Basement Configuration A

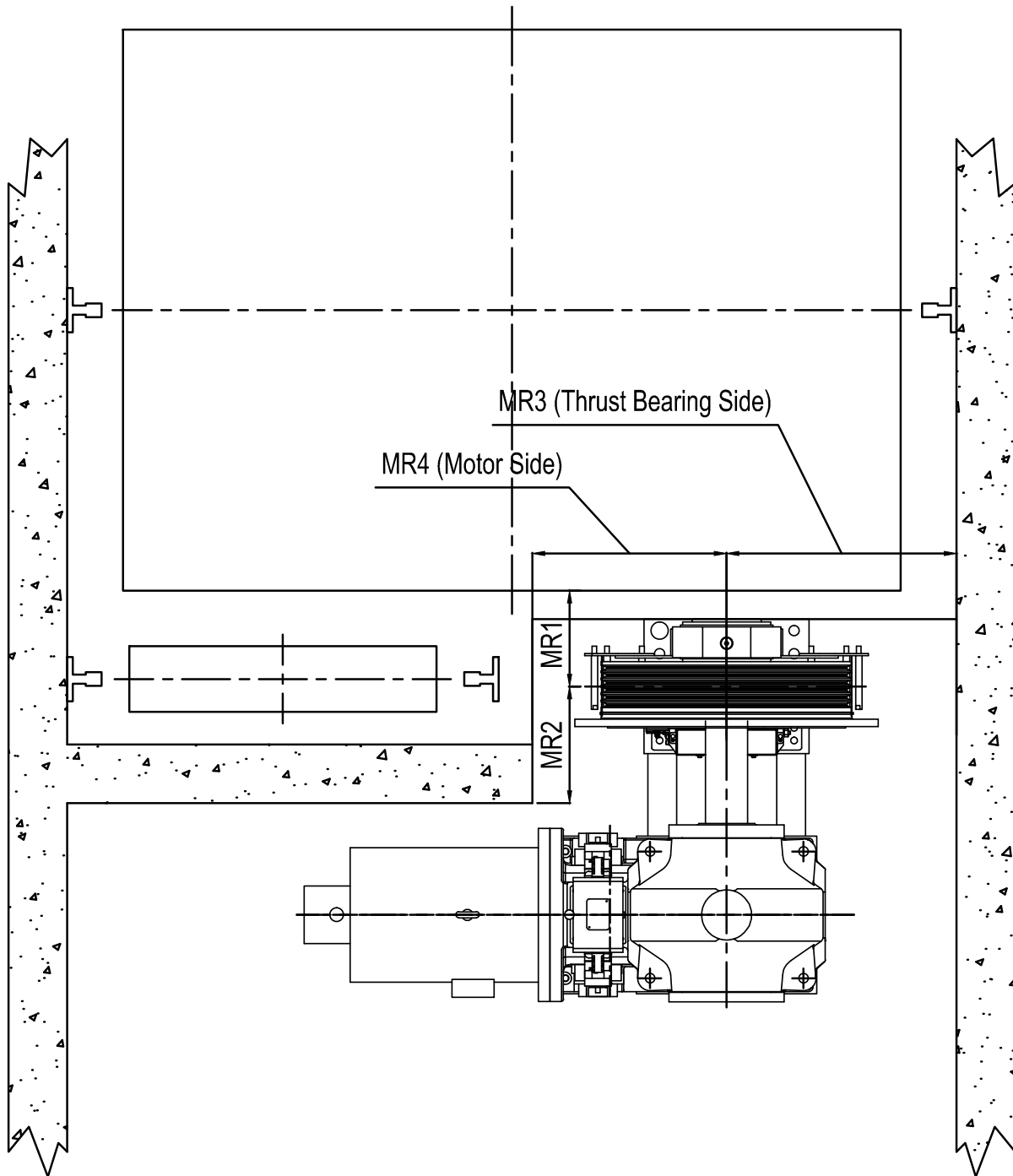

Basement Configuration B

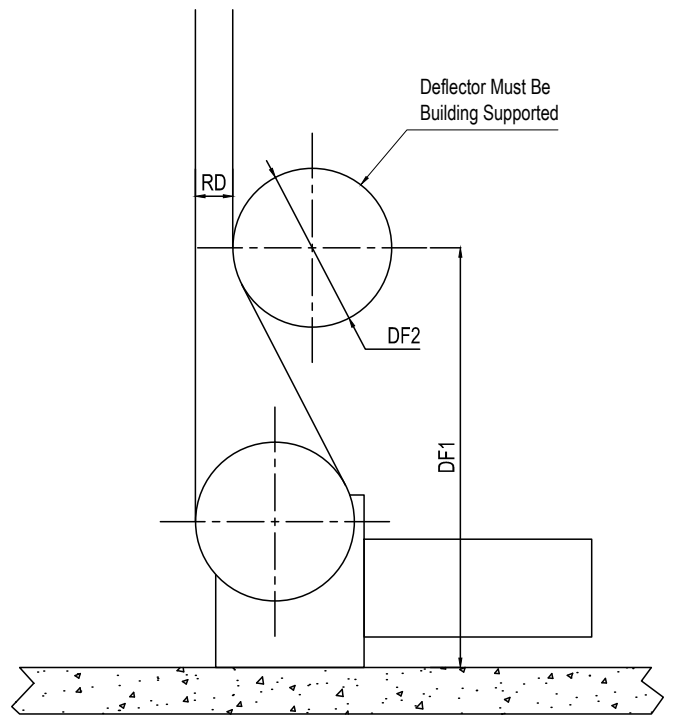
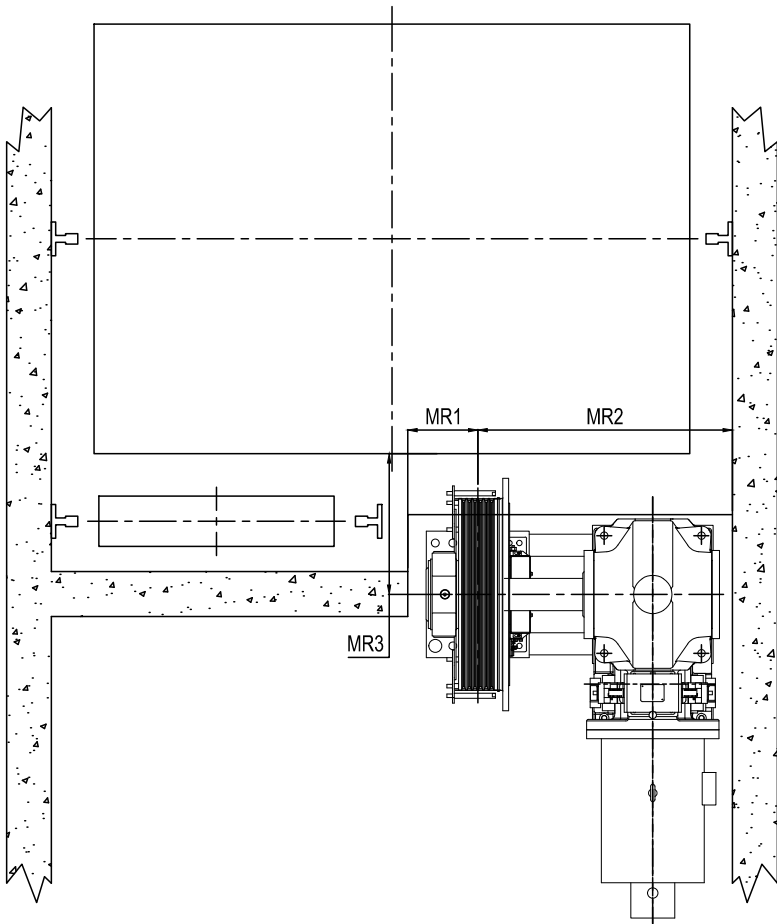

Basement Configuration C

